

### Large Area InGaAs PIN Photodiodes diameter of active area=3 mm

#### DESCRIPTION

Large area, high sensitivity photodiode for use in infrared instrumentation and sensing applications. High spectral response in the region 800 nm to 1700 nm. The photosensitive area is 3 mm in diameter. Planar-passivated device structure.

#### ABSOLUTE MAXIMUM RATINGS (T=25°C)

PARAMETER	RATING	UNITS
Storage Temperature	-40 to +100	°C
Operating Temperature	-40 to +85	°C
Forward Current	50	mA
Reverse Current	10	mA
Reverse Voltage	2	V

#### OPTICAL AND ELECTRICAL CHARACTERISTICS (T=25°C)

PARAMETER	SYMBOL	TEST CONDITIONS	MIN	TYP	MAX	UNITS
Responsivity	R	$\lambda = 1300 \text{ nm}$	0.80	0.90	-	A/W
		$\lambda = 1550 \text{ nm}$	0.90	0.95	-	
Shunt Resistance <sup>1</sup>	$R_s$	$V_R = 0V$	1000	2000	-	K $\Omega$
Capacitance	C	$V_R = 0V$	-	750	1800	pF

<sup>1</sup>Very High Shunt Resistance devices are available upon request.

#### DIMENSIONAL OUTLINE

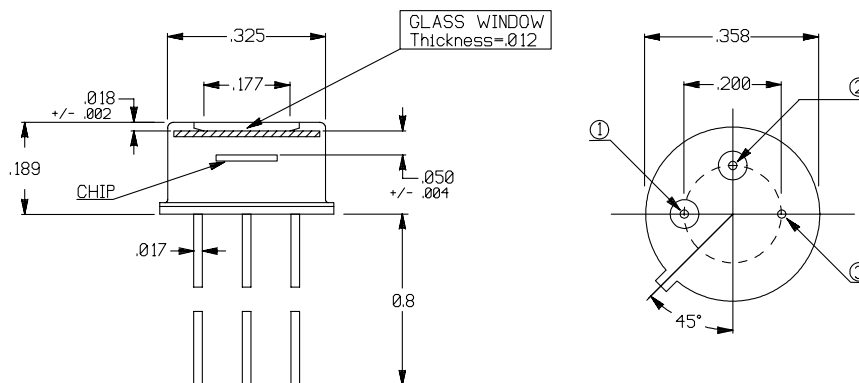

(dimensions in inches)

1	ANODE
2	CATHODE
3	CASE

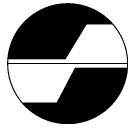

Large Area InGaAs PIN Photodiodes

TYPICAL CHARACTERISTICS

Fig. 1 Spectral Response (R vs.  $\lambda$ )

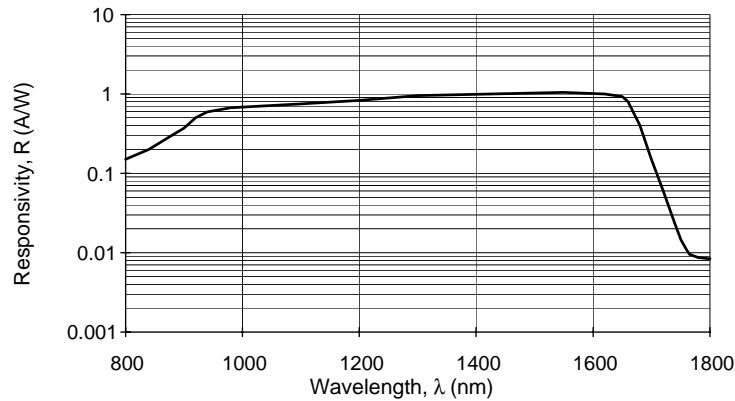

Fig. 2 Dark Current vs. Reverse Voltage

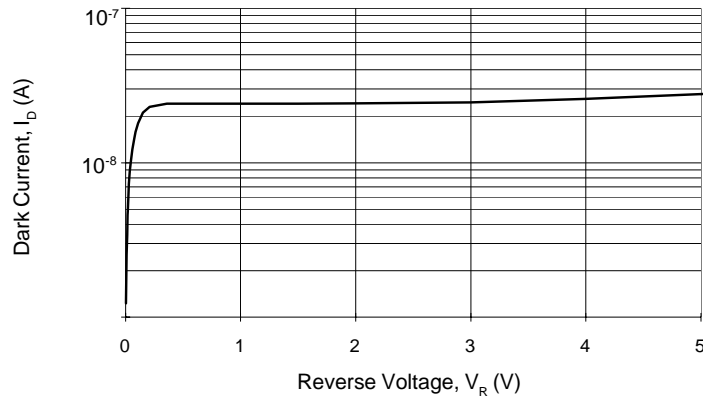

Fig. 3 Capacitance vs. Reverse Voltage

